

OWNER'S MANUAL

36" Chimney Vent Hood

ELEVATE EVERYTHING

MONOGRAM

Introduction

Your new Monogram stainless steel hood makes an eloquent statement of style, convenience and kitchen planning flexibility. Whether you chose it for its purity of design, assiduous attention to detail - or for both of these reasons - you'll find that your Monogram stainless steel hood's superior blend of form and function will delight you for years to come.

Your Monogram stainless steel hood was designed to provide the flexibility to blend in with your kitchen cabinetry. Its sleek design can be beautifully integrated into the kitchen.

The information on the following pages will help you operate and maintain your stainless steel hood properly.

Contents

Consumer Information	2	Troubleshooting Tips	9
Safety Information	4	Warranty	11
Controls and Features		Consumer Support	12
Glass visor	6		
Controls	6		
Care and Cleaning			
For your safety	7		
Metal grease filters	7		
Charcoal filter	7		
Stainless steel surfaces	8		
Painted surfaces	8		
Glass visor	8		
Light bulbs	8		

Before using your chimney hood

Read this manual carefully. It is intended to help you operate and maintain your new stainless steel hood properly.
Keep it handy for answers to your questions.

If you don't understand something or need more help, there is a list of toll-free consumer service numbers included in the back section of this manual.

OR

Visit our Website at: **Monogram.com**

Write down the model & serial numbers

You'll find them on a label behind the filters. These numbers are also on the Consumer Product Ownership Registration Card packed separately with your hood.

Before sending in this card, please write these numbers here:

Model Number

Serial Number

Use these numbers in any correspondence or service calls concerning your hood.

If you received a damaged hood

Immediately contact the dealer (or builder) that sold you the hood.

Save time & money

Before you request service, check the Problem Solver in the back of this manual.

It lists causes of minor operating problems that you can correct yourself.

If you need service

To obtain service, see the Consumer Services page in the back of this manual.

We're proud of our service and want you to be pleased. If for some reason you are not happy with the service you receive, here are some steps to follow for further help.

FIRST, contact the people who serviced your appliance. Explain why you are not pleased. In most cases, this will solve the problem.

NEXT, if you are still not pleased, write all the details—including your phone number—to:

Manager, Customer Relations
Monogram
Appliance Park
Louisville, KY 40225

IMPORTANT SAFETY INFORMATION

READ ALL INSTRUCTIONS BEFORE USING THE APPLIANCE

▲WARNING Read all safety instructions before using the product. Failure to follow these instructions may result in fire, electrical shock, serious injury or death.

▲WARNING GENERAL SAFETY INSTRUCTIONS

▲WARNING TO REDUCE THE RISK OF FIRE, ELECTRIC SHOCK OR INJURY TO PERSONS, OBSERVE THE FOLLOWING:

- A. Use this unit only in the manner intended by the manufacturer. If you have questions, contact the manufacturer.
- B. Before servicing or cleaning unit, switch power off at service panel and lock the service disconnecting means to prevent power from being switched on accidentally. When the service disconnecting means cannot be locked, securely fasten a prominent warning device, such as a tag, to the service panel.
- C. Do not use this unit with any solid-state speed-control device.
- D. This unit must be grounded.

▲CAUTION FOR GENERAL VENTILATING USE ONLY. DO NOT USE TO EXHAUST HAZARDOUS OR EXPLOSIVE MATERIALS AND VAPORS.

▲WARNING TO REDUCE THE RISK OF INJURY TO PERSONS IN THE EVENT OF A RANGE TOP GREASE FIRE, OBSERVE THE FOLLOWING*:

- A. SMOTHER FLAMES with a close-fitting lid, cookie sheet, or metal tray, then turn off the burner. BE CAREFUL TO PREVENT BURNS. If the flames do not go out immediately, EVACUATE AND CALL THE FIRE DEPARTMENT.
- B. NEVER PICK UP A FLAMING PAN—You may be burned.
- C. DO NOT USE WATER, including wet dishcloths or towels—a violent steam explosion will result.
- D. Use an extinguisher ONLY if:
 - 1. You know you have a Class ABC extinguisher, and you already know how to operate it.
 - 2. The fire is small and contained in the area where it started.
 - 3. The fire department is being called.
 - 4. You can fight the fire with your back to an exit.

*Based on "Kitchen Fire safety Tips" published by NFPA.

▲WARNING TO REDUCE THE RISK OF A RANGE TOP GREASE FIRE:

- A. Never leave surface units unattended at high or medium settings. Boilovers cause smoking and greasy spillovers that may ignite. Heat oils slowly on low or medium settings.
- B. Always turn hood ON when cooking at high heat or when flambéing food (i.e. Crepes Suzette, Cherries Jubilee, Peppercorn Beef Flambé).
- C. Clean ventilating fans frequently. Grease should not be allowed to accumulate on fan or filter.
- D. Use proper pan size. Always use cookware appropriate for the size of the surface element.

▲WARNING TO REDUCE THE RISK OF FIRE, ELECTRIC SHOCK OR INJURY TO PERSONS, OBSERVE THE FOLLOWING:

- A. Installation work and electrical wiring must be done by qualified person(s) in accordance with all applicable codes and standards, including fire-related construction.
- B. Sufficient air is needed for proper combustion and exhausting of gases through the flue (chimney) of fuel burning equipment to prevent back drafting. Follow the heating equipment manufacturer's guideline and safety standards such as those published by the National Fire Protection Association (NFPA), and the American Society for Heating, Refrigeration and Air Conditioning Engineers (ASHRAE), and the local code authorities. When applicable, install any makeup (replacement) air system in accordance with local building code requirements. Visit **Monogram.com** for available makeup air solutions.
- C. When cutting or drilling into wall or ceiling, do not damage electrical wiring and other hidden utilities.
- D. Ducted fans must always be vented to the outdoors.

▲WARNING TO REDUCE THE RISK OF FIRE, USE ONLY METAL.

- Do not attempt to repair or replace any part of your hood unless it is specifically recommended in this manual. All other servicing should be referred to a qualified technician.

READ AND SAVE THESE INSTRUCTIONS

CONSIGNES DE SÉCURITÉ IMPORTANTES

VEUILLEZ LIRE TOUTES LES CONSIGNES AVANT D'UTILISER L'APPAREIL

⚠ AVERTISSEMENT

Veillez lire toutes les consignes avant d'utiliser ce produit. Le non-respect de ces instructions pourrait entraîner un incendie, un choc électrique, une blessure grave voire la mort.

⚠ AVERTISSEMENT

CONSIGNES GÉNÉRALES DE SÉCURITÉ

⚠ AVERTISSEMENT

POUR RÉDUIRE LE RISQUE D'INCENDIE, DE SECOURS ÉLECTRIQUE OU DE BLESSURE, OBSERVEZ LES PRÉCAUTIONS SUIVANTES :

- A. N'utilisez cet appareil que de la manière prévue par le fabricant. Si vous avez des questions, appelez le fabricant.
- B. Avant de réparer ou de nettoyer votre appareil, débranchez le courant au niveau du panneau de service et verrouillez les mécanismes de débranchement de service pour éviter tout branchement accidentel au courant. Si vous ne pouvez pas verrouiller les mécanismes de débranchement de service, attachez soigneusement un avertissement bien visible, comme une étiquette, au panneau de service.
- C. N'utilisez jamais cet appareil avec un mécanisme de réglage de la vitesse à semi-conducteurs.
- D. Cet appareil doit être bien mis à la terre.

⚠ ATTENTION

UNIQUEMENT À USAGE DE VENTILATION GÉNÉRALE. N'UTILISEZ JAMAIS POUR L'ÉCHAPPEMENT DE MATIÈRES ET DE VAPEURS EXPLOSIVES.

⚠ AVERTISSEMENT

POUR RÉDUIRE LE RISQUE DE BLESSURE CORPORELLE SI DE LA GRAISSE PREND FEU SUR LA SURFACE DE CUISSON DU FOUR, SUIVEZ LES INSTRUCTIONS SUIVANTES* :

- A. **ÉTOUFFEZ LES FLAMMES** avec un couvercle qui convient, une tôle à biscuits ou un plateau en métal, puis éteignez le brûleur. FAITES BIEN ATTENTION DE NE PAS VOUS BRÛLER. Si les flammes ne s'éteignent pas immédiatement, **SORTEZ ET APPELEZ LES POMPIERS.**
- B. **NE DÉPLACEZ JAMAIS UNE CASSEROLLE QUI FLAMBE**— Vous pouvez vous brûler.
- C. **N'UTILISEZ JAMAIS D'EAU**, en particulier de serviette ou de chiffon mouillé—il se produira une explosion violente de vapeur brûlante.
- D. **N'UTILISEZ UN EXTINCTEUR** que si :
 1. Vous avez un extincteur de classe ABC et vous savez comment l'utiliser;
 2. Le feu est réduit et confiné à l'endroit où il a commencé;
 3. Vous avez déjà appelé les pompiers;
 4. Vous combattez les flammes en tournant le dos à une sortie.

* Basé sur l'ouvrage intitulé «Kitchen Fire Safety Tips» publié par la NFPA.

⚠ AVERTISSEMENT

RÉDUISEZ LE RISQUE D'UN FEU DE GRAISSEUR LA SURFACE DE CUISSON DU FOUR:

- A. Ne laissez jamais sans surveillance les unités de cuisson de surface à une température élevée. Le bouillonnement occasionne des débordements fumants et graisseux qui peuvent prendre feu. Chauffez à feu doux les substances huileuses, avec un réglage bas ou moyen.
- B. Mettez toujours la hotte en marche quand vous cuisinez à haute température ou quand vous faites flamber des aliments (p. ex. crêpes Suzette, cerises Jubilee, Bœuf flambé Peppercorn).
- C. Nettoyez les mécanismes de ventilation fréquemment. Il ne faut pas permettre une accumulation de graisse sur le ventilateur ou sur le filtre.
- D. Utilisez une casserole de bonne taille. Utilisez toujours un ustensile de cuisine qui convienne au diamètre de l'élément de cuisson.

⚠ AVERTISSEMENT

POUR RÉDUIRE LE RISQUE D'INCENDIE, DE SECOURS ÉLECTRIQUE OU DE BLESSURE CORPORELLE, OBSERVEZ LES PRÉCAUTIONS SUIVANTES :

- A. Vous devez faire exécuter tous les travaux d'installation et de câblage électrique par une personne qualifiée, conformément à tous les codes et les normes en vigueur, en particulier ceux de construction relatifs aux incendies.
- B. Vous devez assez d'air pour avoir une bonne combustion et permettre l'évacuation des gaz par le conduit de cheminée du matériel de combustion du carburant, afin d'éviter tout retour d'air. Suivez les directives du fabricant de matériel de combustion et les normes de sécurité comme celles publiées par la National Fire Protection Association (NFPA) et l'American Society for Heating, Refrigeration and Air Conditioning Engineers (ASHRAE), ainsi que les modalités des codes locaux. Le cas échéant, installez un système de compensation d'air (remplacement) conformément aux conditions des codes locaux du bâtiment. Visitez le site **Monogram.com** pour connaître les solutions offertes en matière de système de compensation d'air.
- C. Si vous faites un trou ou une ouverture dans un mur ou un plafond, n'endommagez pas les fils électriques et les autres installations cachées de service public.
- D. Vous devez toujours alimenter les ventilateurs dans les conduits en air en provenance de l'extérieur.

⚠ AVERTISSEMENT

POUR RÉDUIRE LE RISQUE D'INCENDIE, N'UTILISEZ QUE DES CONDUITS EN MÉTAL.

- N'essayez jamais de remplacer ou de réparer un élément de votre hotte si le présent manuel ne le recommande pas expressément. Tout autre entretien doit être effectué par un technicien qualifié.

LISEZ CES INSTRUCTIONS ET RANGEZ-LES SOIGNEUSEMENT

Glass visor

Grasp the visor and pull it out to more efficiently remove steam when cooking. Push it back when not in use.

NOTE: The vent fan will work with the visor in or out.

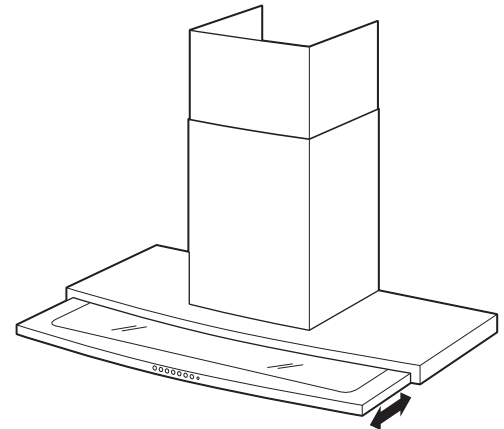

Controls

NOTE: Avoid using food products that produce flames under the range hood.

- 1 Light ON/OFF. It remembers the last light level used. (Six light levels.)
- 2 Dims the light.
- 3 Brightens the light.
- 4 ON/OFF. It remembers the last fan speed used. (Four speed fan.)
- 5 Decreases the speed.
- 6 Increases the speed.
- 7 BOOST—The highest fan speed.

NOTE: The BOOST fan speed can only be selected with this control. BOOST is not accessible by cycling up to the highest fan speed using the increase fan button.

- 8 Fan indicator. The light will turn on when the fan is operating.

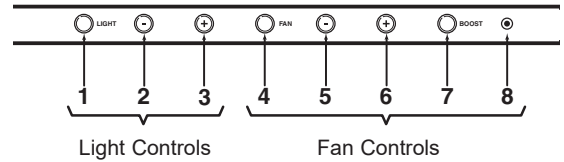

For your safety

Before servicing or cleaning unit, switch power off at service panel and lock the service disconnecting means to prevent power from being switched on accidentally.

When the service disconnecting means cannot be locked, securely fasten a prominent warning device, such as a tag, to the service panel.

Metal grease filters

The metal filters trap grease released by foods on the cooktop. The filters also help prevent flames (from food, grease) from damaging the inside of the hood.

For this reason, the filters must ALWAYS be in place when the hood is used. The grease filters should be cleaned every 6 months, or as needed.

To clean the grease filters, soak them and then swish them around in hot water and detergent. Don't use ammonia or ammonia products because they will darken the metal. Do not use abrasives or oven cleaners. Light brushing can be used to remove embedded dirt. Rinse, shake and let them dry before replacing.

The metal grease filters may also be cleaned in an automatic dishwasher.

To remove:

Pull the visor out. Grasp the filter lock and pivot it open to release. Pull the filter down and out. Remove both filters.

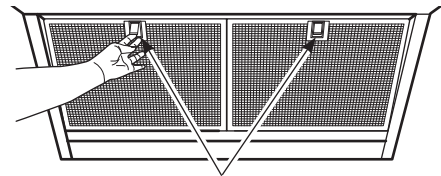

Filter Locks

To replace:

1. Insert the two tabs on the bottom filter edge into the slots in the back of the hood.
2. Push the front of the filter up, open the filter lock and snap it into place in the hood.

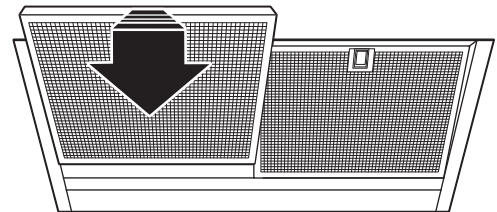

Charcoal filter (on some models)

If the model is not vented to the outside, the air will be recirculated through a disposable charcoal filter that helps remove smoke and odors.

The charcoal filter should be replaced when it is noticeably dirty or discolored (usually after 6 to 12 months, depending on hood usage).

NOTE: DO NOT rinse, or put charcoal filter in an automatic dishwasher.

The charcoal filter cannot be cleaned. It must be replaced.

Order Charcoal Filter WB02X11343.

This filter can be ordered from your Monogram Supplier.

To remove:

1. Pull the visor out.
2. Remove the two metal filters—see Metal grease filters section above.
3. Grasp the front of the charcoal filter and pull it down and out.

To replace:

Insert the back of the charcoal filter edge into the opening in the rear (center), push the front of the filter up and snap it into place in the hood. Replace the two metal filters.

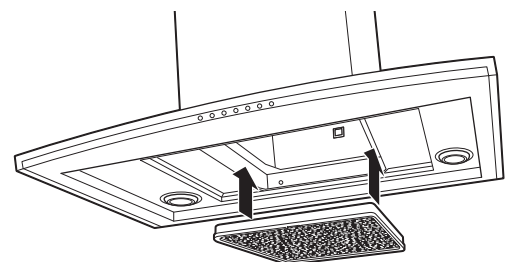

Stainless steel surfaces (on some models)

Do not use a steel wool pad; it will scratch the surface.

To clean the stainless steel surface, use warm sudsy water, a stainless steel cleaner such as Kleen King® or an all-purpose liquid or spray cleaner. Always scrub in the direction of the grain. Rinse thoroughly with a sponge or cloth and clean water. Dry with a soft, clean cloth.

After cleaning, use a stainless steel polish, such as Stainless Steel Magic®, Revere Copper and Stainless Steel Cleaner® or Weno! All Purpose Metal Polish®. Follow the product instructions for cleaning the stainless steel surface.

Painted surfaces (on some models)

Clean any painted surfaces with a mixture of water and either soap or vinegar.

Do not use commercial oven cleaners, cleaning powders, steel wool or harsh abrasives on any painted surface.

Glass visor

Pull the glass visor out and wash it with a damp soapy cloth. Dry it with a clean cloth and push it back into place.

Light bulbs

NOTE: The glass cover should be removed only when cold. Wearing latex gloves may offer a better grip.

⚠ CAUTION

Before replacing the bulb, disconnect electrical power to the hood at the main fuse or circuit breaker panel.

⚠ ATTENTION

Avant de remettre en place l'ampoule, débranchez le courant de la hotte en enlevant le fusible principal ou en faisant basculer le disjoncteur au panneau d'alimentation.

Be sure to let the light cover and bulb cool completely.

For your safety, do not touch a hot bulb with bare hands or a damp cloth.

To remove:

- 1 Insert your finger nail into the inner glass cover slot and pull down. Remove cover.

NOTE: Do not remove outer retaining ring.

- 2 Using gloves or a dry cloth, remove the bulb by pulling it straight out.

To replace:

- 1 Use a new 12-volt, 20-watt Halogen bulb for a G-4 base.
- 2 Using gloves or a dry cloth, remove the new bulb from its packaging.

NOTE: Do not touch the new halogen bulb with bare fingers. Touching the bulb with bare fingers will significantly reduce the life of the bulb.

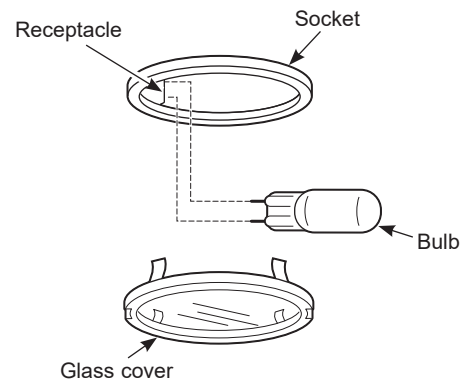

ONLY use a new 12-volt, 20-watt Halogen bulb for a G-4 base.

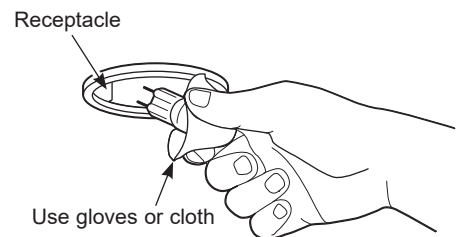

- 3 Push the bulb straight into the receptacle all the way.

For improved lighting, clean the glass cover frequently using a damp cloth. This should be done when the hood is completely cool.

- 4 Snap the glass cover into the retaining ring.
- 5 Reconnect electrical power to the hood.

*Before you
call for service*

Save time and money! Review the charts on the following pages first and you may not need to call for service.

Problem	Possible Cause	What To Do
Fan does not operate when the switch is on	A fuse may be blown or a circuit breaker tripped.	Replace fuse or reset circuit breaker.
Fan fails to circulate air	Fan blade striking the hood shell.	Excessively soiled filter should be checked and corrected before using the hood again.
	Sufficient makeup (replacement) air is required for exhausting appliances to operate to rating.	Check with local building codes, which may require or strongly advise the use of makeup air. Visit Monogram.com for available makeup air solutions.
Fan operates but moves air slower than normal		Check to be sure the filter is clean . If replacing the filter does not correct the problem, call for service.
Fan keeps going off and on	The motor is probably overheating and turning itself off. This can be harmful to the motor.	Check to be sure the filter is clean . If it continues to cycle on and off, call for service.
Fan light is on or is blinking	This is normal and indicates the fan is operating as it should.	

Notes

YOUR MONOGRAM VENT HOOD WARRANTY

Staple sales slip or cancelled check here. Proof of original purchase date is needed to obtain service under warranty.

WHAT IS COVERED

From the Date of the Original Purchase

LIMITED TWO-YEAR WARRANTY

For two years from date of original purchase, we will provide, free of charge, parts and service labor in your home to repair or replace **any part of the vent hood** that fails because of a manufacturing defect.

This warranty is extended to the original purchaser and any succeeding owner for products purchased for ordinary home use in the 48 mainland states, Hawaii, Washington, D.C. or Canada. If the product is located in an area where service by a Monogram Authorized Servicer is not available, you may be responsible for a trip charge or you may be required to bring the product to an Authorized Monogram Service location for service. In Alaska the warranty is the same except that it is LIMITED because you must pay to ship the product to the service shop or for the service technician's travel costs to your home.

All warranty service will be provided by our Factory Service Centers or by our authorized Customer Care® servicers during normal working hours.

Should your appliance need service, during warranty period or beyond, in the USA call 800.444.1845. In Canada: 888.880.3030. Please have your serial number and model number available when calling for service.

WHAT IS NOT COVERED

- Service trips to your home to teach you how to use the product.
- Replacement of house fuses or resetting of circuit breakers.
- Incidental or consequential damage caused by possible defects with this appliance.
- Replacement of the filters.
- Damage to the product caused by accident, fire, floods or acts of God.
- Failure of the product if it is used for other than its intended purpose or used commercially.
- Improper installation, delivery or maintenance. If you have an installation problem, contact your dealer or installer. You are responsible for providing adequate electrical, gas, exhausting and other connecting facilities as described in the Installation Instructions provided with the product.
- Damage caused after delivery.
- Product not accessible to provide required service.
- Installation of service for a makeup (replacement) air system.

EXCLUSION OF IMPLIED WARRANTIES

Your sole and exclusive remedy is product repair as provided in this Limited Warranty. Any implied warranties, including the implied warranties of merchantability or fitness for a particular purpose, are limited to one year or the shortest period allowed by law.

Some states do not allow the exclusion or limitation of incidental or consequential damages, so the above limitation or exclusion may not apply to you. This warranty gives you specific legal rights, and you may also have other rights which vary from state to state.

To know what your legal rights are in your state, consult your local or state consumer affairs office or your state's Attorney General.

Warrantor: GE Appliances, a Haier company

Warrantor in Canada: MC COMMERCIAL INC, Burlington, ON, L7R 5B6

With the purchase of your new Monogram appliance, receive the assurance that if you ever need information or assistance from Monogram, we will be there. All you have to do is call!

Register Your Appliance

Register your new appliance on-line at your convenience! Timely product registration will allow for enhanced communication and prompt service under the terms of your warranty, should the need arise. You may also mail in the pre-printed registration card included in the packing material.
In the US: **Monogram.com**
In Canada: **Prodsupport.mabe.ca/crm/Products/ProductRegistration.aspx**

Schedule Service

Expert Monogram repair service is only one step away from your door. Get on-line and schedule your service at your convenience any day of the year.
In the US: **Monogram.com**
or call 800.444.1845 during normal business hours.
In Canada: **GEAppliances.ca/en/support/service-request** or call 888.880.3030

Extended Warranties

Purchase a Monogram extended warranty and learn about special discounts that are available while your warranty is still in effect.
In the US: **Monogram.com**
or call 800.444.1845 during normal business hours.
In Canada: **GEAppliances.ca/en/support/purchase-extended-warranty** or call 888.880.3030

Remote Connectivity

For assistance with wireless network connectivity (for models with remote enable), visit our website at **Monogram.com** or call 800.444.1845 in the US only.

Parts and Accessories

Individuals qualified to service their own appliances can have parts or accessories sent directly to their homes (VISA, MasterCard and Discover cards are accepted). Order on-line today 24 hours every day.
In the US: **Monogram.com** or by phone at 800.444.1845 during normal business hours.

Instructions contained in this manual cover procedures to be performed by any user. Other servicing generally should be referred to qualified service personnel. Caution must be exercised, since improper servicing may cause unsafe operation.

Customers in Canada should consult the yellow pages for the nearest MC Commercial service center, visit our website at **GEAppliances.ca/en/products/parts-filters-accessories** or call 888.880.3030.