



# Air Conditioner

## Owner's Manual

### *Chassis Only*

**Cool Only:** AJCH 08, 10 AC

AJCH 10, 12 DC

AJCS 06 LC

AJCS 08, 10, AC

AJCS 09, 10, 12 DC

**Heat/Cool:** AJES 09, 10, 12 DC

AJEH 12 DC

**Heat Pump:** AJHS 08, 10 DC

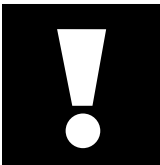

## **Important Safety Information**

**3**

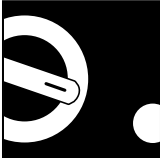

## **Operating Instructions**

*The Controls on Your Air Conditioner  
Care of Product*

**4**



## **Installation Instructions**

*Important Electrical Safety  
Installing a J-Model in an Existing Wall Case*

**8**

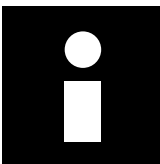

## **Helpful Information**

*Things That Are Normal*

**11**



## **If Something Goes Wrong**

*Before You Call for Service  
GE Service Numbers  
Warranty*

**12**

**GE Answer Center<sup>®</sup>**

**800.626.2000**

*GE Appliances*

## Welcome

Welcome to the GE family. We're proud of our quality products and we believe in dependable service. You'll see it in this easy-to-use manual and you'll hear it in the friendly voices of our customer service department.

Best of all, you'll experience these values each time you enjoy the comfort of your air conditioner. That's important, because your new air conditioner will be part of your family for a long time.

## Start Here!...Before using your air conditioner

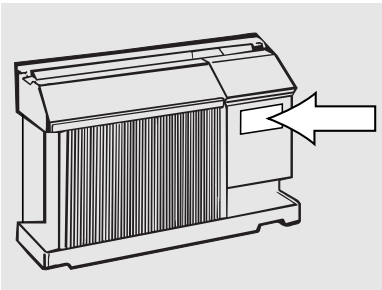

**Write down the model and serial numbers here.** They are on a label on the front of the control box behind the front grille.

---

**Model number**

---

**Serial number**

---

**Date of purchase**

**Staple your receipt to the inside back cover of this manual. You will need it to obtain service under warranty.**

## Need Help?

*Help us  
help you*

**800.626.2000**

Before you call for service, there are a few things you can do to help us serve you better.

**Read this manual.** It contains instructions to help you use and maintain your air conditioner properly.

**Save time and money.** Check the section titled "If Something Goes Wrong" before calling. This section helps you to solve common problems that might occur.

If you do need service, you can relax knowing help is only a phone call away. A list of toll-free customer service numbers is included in the back of this book. Or call the GE Answer Center<sup>®</sup> at 800.626.2000, 24 hours a day, 7 days a week.

## IMPORTANT SAFETY INFORMATION



### READ ALL SAFETY INFORMATION BEFORE USING

- This air conditioner must be properly installed in accordance with the Installation Instructions before it is used.
  - Repair or replace immediately all electric service cords that have become frayed or otherwise damaged.
  - Turn the selector control to **OFF** and unplug your air conditioner before making any repairs.
- NOTE:** We strongly recommend that any servicing be performed by a qualified individual.

#### Extension Cord 115V

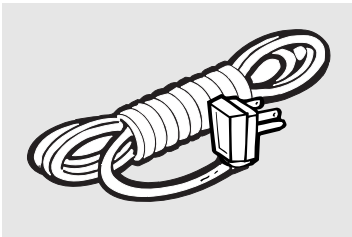

The use of an extension cord is not recommended. However, if an extension cord is required to reach the nearest wall receptacle, use only a UL-listed, 3-wire, grounded, 14 gauge, 15A, 125V appliance extension cord.

#### **⚠ CAUTION:**

**DO NOT use an extension cord with any of the 208/230-volt models.**

#### Adapter Plug 115V

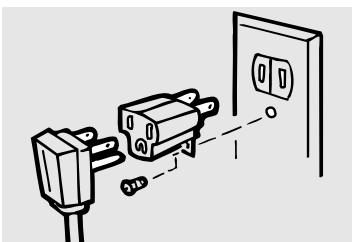

This is a temporary method. UL-listed adapters are available at most hardware stores.

Because most 2-prong outlets are not grounded, we strongly advise against using an adapter plug. However, a temporary connection may be made where local codes permit and if the 2-prong wall outlet is properly grounded.

When you plug the adapter in, make sure the larger prong goes into the larger slot to provide the proper polarity for the power cord.

#### **FOR PROPER GROUNDING:**

- 1 Screw the adapter to the outlet, using the outlet cover screw.**
- 2 Ground the outlet through the house wiring.**

When disconnecting the power cord from the adapter, hold the adapter close to the outlet while pulling the plug out. If this is not done, the grounding connector is likely to break with repeated use.

If the grounding connector breaks, **DO NOT USE** the air conditioner until a proper ground has again been made.

## SAVE THESE INSTRUCTIONS

# Operating Instructions

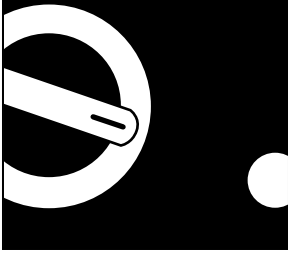

The controls on your air conditioner

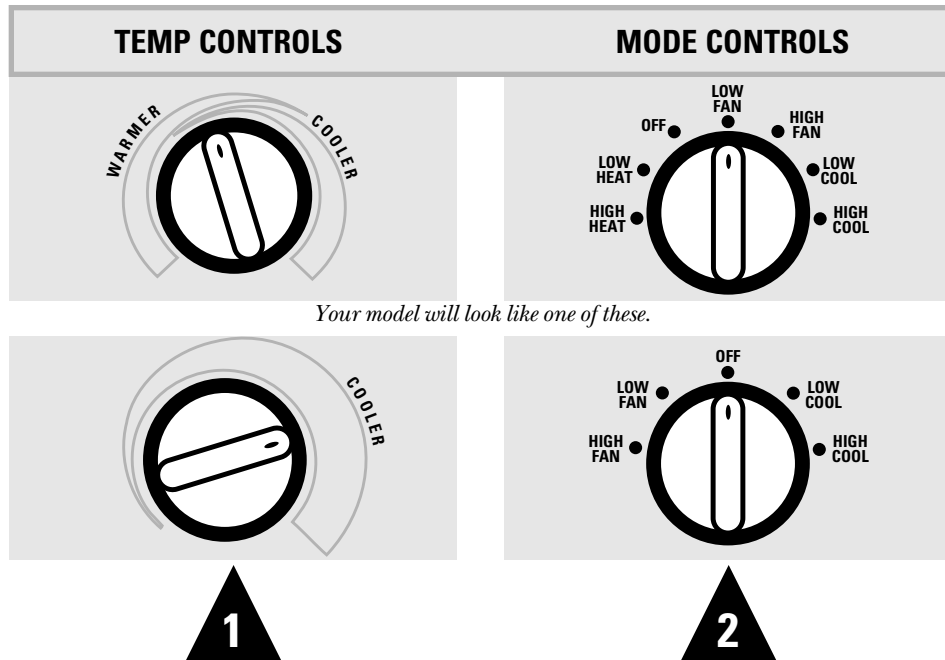

## 1 Temp Control

The temp control is used to maintain the room temperature. The compressor will cycle on and off to keep the room at the same level of comfort. When you turn the knob to **COOLER** (blue) the indoor air will become cooler. Turn the knob to **WARMER** (red) and the indoor air will become warmer.

### HEAT PUMP MODELS

When the outdoor temperature is lower than 25°F., heat is provided by the electric heater in the air conditioner instead of by the heat pump.

## 2 Mode Control

**HIGH COOL** and **LOW COOL** provide cooling with different fan speeds.

**HIGH HEAT** and **LOW HEAT** provide heating with different fan speeds.

**LOW FAN** or **HIGH FAN** provides air circulation and filtering without cooling or heating.

### NOTE:

**If you move the switch from a cool or heat setting to OFF or to a fan setting, wait at least 3 minutes before switching back to a cool or heat setting.**

**A 3-minute delay is automatically provided on the Heat/Cool and Heat Pump models.**

# Cooling/Heating Descriptions



## FOR NORMAL COOLING OR HEATING

Select **HIGH COOL** or **HIGH HEAT** with the thermostat at mid point.

## FOR MAXIMUM COOLING

Select **HIGH COOL** with the thermostat at maximum cool.

## FOR MAXIMUM HEATING

Select **HIGH HEAT** with the thermostat at maximum heat.

## FOR QUIETER & NIGHTTIME COOLING

Select **LOW COOL** or **LOW HEAT** with the thermostat at mid point.

*Features and appearance may vary.*

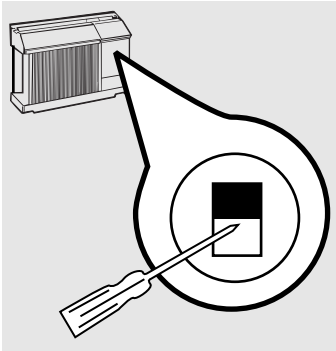

3

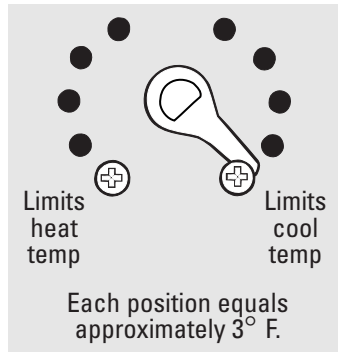

4

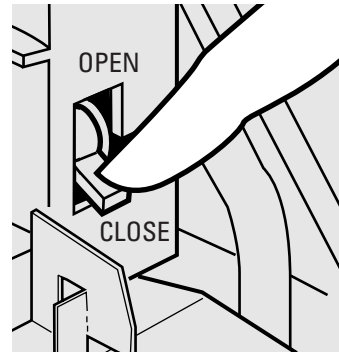

5

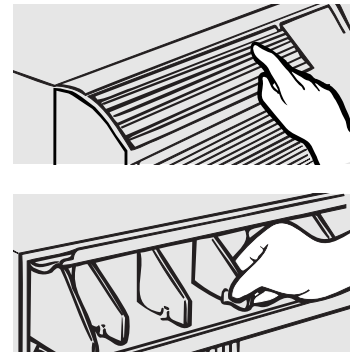

6

## 3 Fan Switch

On Heat/Cool models, the fan switch lever is located in a hole through the control panel. To reach it, you need to remove the front grille. Use a small screwdriver to change the setting. Cool only models have a rocker switch on the front of the control box.

When set at **CYCLE** (down) the fan cycles on and off when cooling or heating. When set at **CONT** (continuous, up) the fan runs all the time. The unit is shipped in the **CONT** setting.

## 4 Temperature Limiting

Limiting the maximum and minimum settings prevents users from turning the control to the extreme heat or cool positions.

The normal range of the temp control is approximately 60° F to 85° F. The control range may be narrowed by the use of the temperature limiting screws located behind the control panel.

## 5 Vent Control

The vent control is located behind the front grille. When set at **CLOSE**, only the air inside the room will be circulated and conditioned. You may adjust it by removing the front grille. When set at **OPEN**, some inside air is exhausted outside.

**NOTE:** The vent lever is taped in the **CLOSE** position when it leaves the factory. Remove the tape before using.

## 6 Air Direction

Horizontal louvers on the front grille let you control the air direction up and down.

Remove the front grille to adjust the vertical louvers side-to-side to direct the air left or right.



# Operating Instructions

## Care & Cleaning

### Grille and Case

Turn the air conditioner off and remove the plug from the wall outlet before cleaning.

To clean, use water and a mild detergent. Do not use bleach or abrasives.

### Outdoor Coils

The coils on the outdoor side of the air conditioner should be checked regularly. It is necessary to remove the air conditioner from the wall case to inspect them. Dirt build-up occurs on the surface which is not visible from the outside. If they are clogged with dirt or soot it will reduce the cooling or heating performance and the unit will not work properly.

They may be professionally steam cleaned, a service available through your GE service outlet.

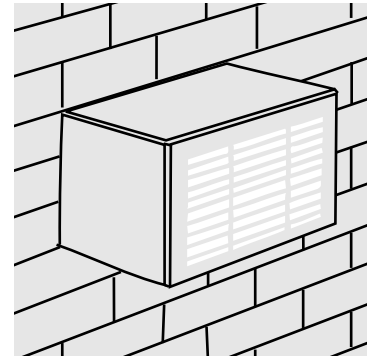

### Front Grille

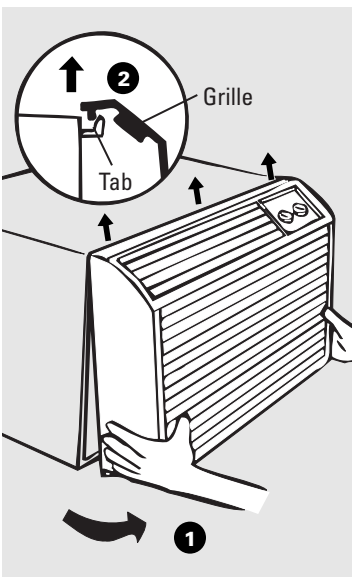

The front grille can be removed for more thorough cleaning or to make the model and serial numbers accessible.

#### To remove:

Pull out from the bottom and lift up from the tabs on the top of the case.

#### To replace:

Hook the tabs on the front grille even with the tabs on the front of the case and snap into place.

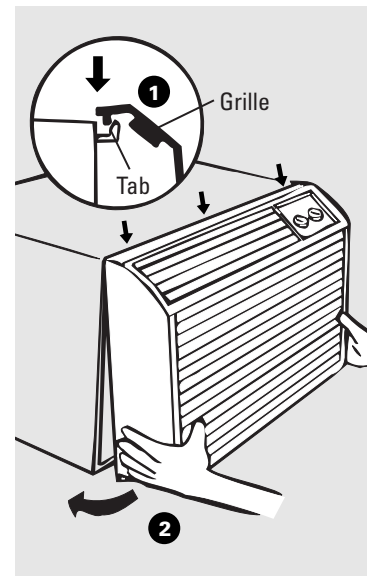



## Air Filter

**Operating Tip:**  
**To maintain optimum performance, clean the filter at least every 30 days.**

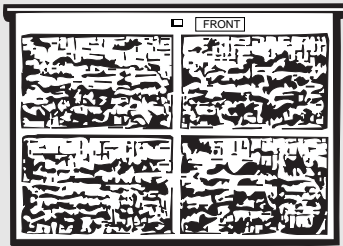

Dirty filter—Needs cleaning

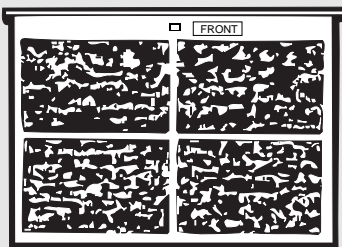

Clogged filter—Greatly reduces cooling, heating and airflow.

### **Turn the air conditioner off before cleaning.**

The most important thing you can do to maintain the air conditioner is to clean the filter at least every 30 days. Clogged filters reduce cooling, heating and airflow.

### **Keeping the filter clean will:**

- Decrease cost of operation.
- Save energy.
- Prevent clogged heat exchanger coils.
- Reduce the risk of premature component failure.

### **To clean the air filter:**

- Vacuum off the heavy soil.
- Run water through the filter from the back side.
- Dry thoroughly before replacing.

**On some models,** carefully pull the tab forward, up and out.

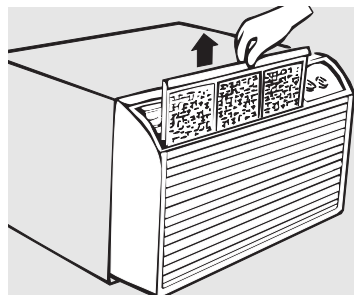

**On other models,** pull it down.

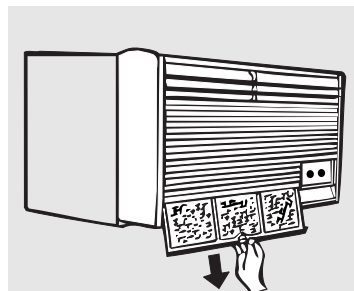

Replace the clean filter by pushing it back into place.

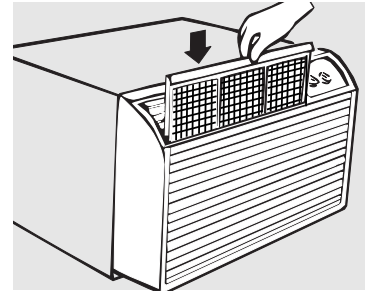

### **CAUTION:**

**DO NOT operate the air conditioner without the filter in place. If a filter becomes torn or damaged it should be replaced immediately.**

Operating without the filter in place or with a damaged filter will allow dirt and dust to reach the indoor coil and reduce the cooling, heating, airflow and efficiency of the unit.

Replacement filters are available from your salesperson, GE dealer, GE Service and Parts Center or authorized Customer Care® servicers.





## Installation Instructions

### *Important Electrical Safety—Read Carefully*

**Installer:** Leave these instructions with the appliance.

**Owner:** Keep these instructions for future use.

#### **Important Notes**

- **The satisfactory operation of this air conditioner is dependent upon it being installed in a wall case, and used with an exterior grille, both specifically designed for use with this unit.** Use with an incorrect wall case or with an incorrect grille may result in poor performance and could cause damage to the unit. If you are not sure if you have the correct wall case and the rear grille please contact the company where you purchased the unit.
  - For personal safety, this air conditioner must be properly grounded.
  - It is important to have the wall outlet and circuit checked by a qualified electrician if there is any doubt as to whether a proper ground exists.
  - Follow National Electrical Code (NEC) or local codes and ordinances.
- ⚠ CAUTION:**
- **Do not, under any circumstances, cut or remove the third (ground) prong from the power cord.**
  - **Do not change the plug on the power cord of this air conditioner.**
  - **Aluminum house wiring may present special problems—consult a qualified electrician.**

#### **Electrical Requirements**

We recommend that **the 230/208-volt, 60 Hz models** be installed on their own single branch circuit supplying 230/208-volt a.c., protected with a time delay fuse or circuit breaker.



**Parallel**  
115V.  
15 Amp.



**Perpendicular**  
230/208V.  
20 Amp.



**Tandem**  
230/208V.  
15Amp.

This is recommended for best performance and to prevent overloading house or apartment wiring circuits, which could cause a possible fire hazard from overheating wires.

**The 115-volt models** require a 115/120-volt a.c., 60 Hz grounded outlet protected with a 15-amp time delay fuse or circuit breaker.

The 3-prong grounding plug minimizes the possibility of electric shock hazard. If the wall outlet you plan to use is only a 2-prong outlet, it is your responsibility to have it replaced with a properly grounded 3-prong wall outlet.





# Installing a J-Model in an Existing Wall Case

## J-Model Qualifying Questions

### **IMPORTANT!**

**GE strongly recommends the removal of the old wall case and the installation of a new GE Wall Case. If you decide to keep the existing wall case, you may need a kit to ensure proper performance. If you DO NOT use a kit, you run the risk of poor performance or product failure. This is not covered under the terms of the GE warranty.**

J-model air conditioners may fit in existing wall cases. However, they often need a kit to properly adapt the case to the GE air conditioner. Answer these questions and see the chart below for the proper kit.

### **1 What brand air conditioner will you be replacing?**

### **2 What are the dimensions of the wall case currently in use?**

### **3 What is the model number of the chassis currently in use? What is the model (or Type) number of the wall case currently in use?**

Frequently, the J-model adapter kit will apply to another brand model “series” or specific vintage. In these cases, you need the chassis model number and/or the wall case or “type” number to confirm the use of the correct adapter kit.

### **4 What type of outdoor grille is used with the current wall case?**

There may be an architectural grille attached to a wall case to enhance the exterior appearance of the building. Custom grilles may be used with J-model wall cases provided a J-model adapter kit is also used to ensure proper airflow.

<b>Use GE Kit Number:</b>	<b>For:</b>	<b>Description:</b>
<b>RAK56A100</b>	GE RAB13, 14 & 15 (ACLB & RCL Chassis)	Fits all GE wall cases 26"W × 18"H × 24"D
<b>RAK107</b>	Hotpoint ACXB10 & 11 (ACTB Chassis)	Adapts an older Hotpoint wall case to a “J” model chassis. Fits Hotpoint wall cases 25¾"W × 16⅞"H × 18⅝"D
<b>RAK108</b>	Whirlpool Type 23W Wall Case	Adapts Whirlpool wall case to a “J” model chassis. Fits Whirlpool wall cases 25⅞"W × 16½"H × 23⅞"D
<b>RAK110</b>	GE RAB30 (“F” models)	Adapts GE wall case to a “J” model chassis. Fits the RAB 30 wall case 26"W × 18"H × 24"D
<b>RAK123</b>	Fedders Wall Case “A”	Adapts Fedders wall case to a “J” model chassis. Fits Fedders wall cases 27"W × 16¾"H × 16¾"D
<b>RAK126</b>	Westinghouse Wall Case (Type 2626D73H01)	Adapts Westinghouse wall case to a “J” model chassis. Fits Westinghouse wall cases 25⅞"W × 15⅞"H × 16"D
<b>RAB46, 47 &amp; 48</b>	Use these kits for all other brands not listed.	Standard wall case for “J” model chassis. RAG13 stamped aluminum exterior grille included. Remove the existing case and replace.
<b>RAK690</b>	RAB36, 37, 38, 46, 47 or 48 (J-Chassis)	If you attach a custom architectural outdoor grille, use this kit to ensure proper airflow.
<b>RAG14E</b>	RAB36, 37, 38, 46, 47 or 48 (J-Chassis)	Architectural louvered exterior grille



# Installation Instructions

## Install the Air Conditioner in the Case

**1** Remove the locking plate on the front left side.

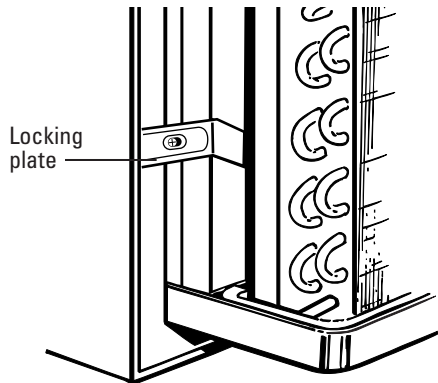

**2** Remove the shipping pad inside the air conditioner next to the compressor.

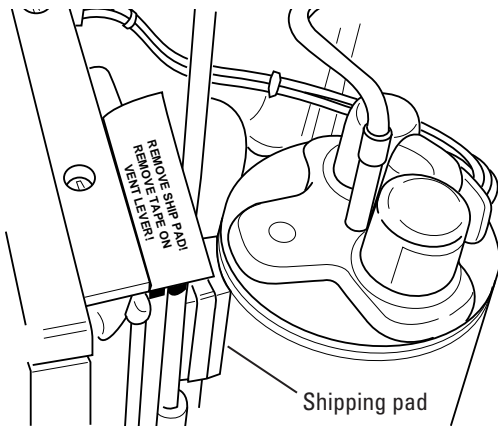

**3** Carefully slide the air conditioner back into the case. Make sure that the tubing on the unit does not touch the wall case and that the case installation is secure.

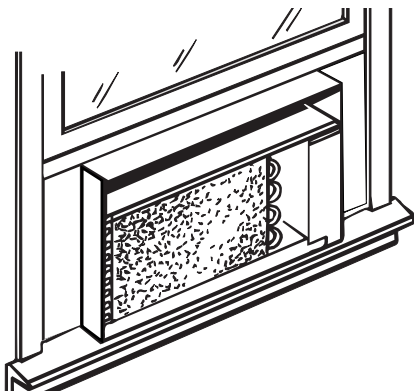

**4** Reinstall the locking plate with the tab behind the wall case flange. Tighten the screw.

**5** Attach the power cord to the base pan with the clamp.

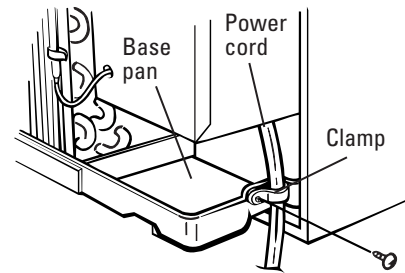

**6** When the wall outlet is to the left, extend the cord under the unit and hold it in place with the clamp.

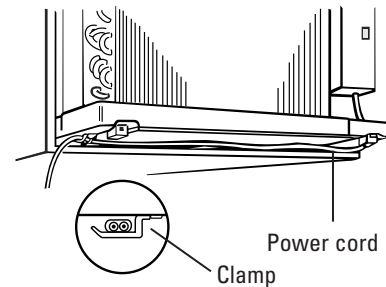



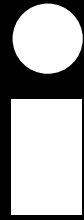

**7** Attach the front grille. An opening for the power cord is on the bottom of the front grille.

## Helpful Information



### Things That Are Normal

Noise	Explanation
<b>PING!</b> 	You may hear a pinging noise caused by water being picked up and thrown against the condenser on rainy days or when the humidity is high. This design feature helps remove moisture and improve efficiency.
<b>"CLICK"</b> 	You may hear the thermostat click when the compressor cycles on and off.
<b>DRIP</b> 	Water will collect in the base pan during high humidity or on rainy days. The water may overflow and drip from the outdoor side of the unit. On the heat pump units, water will drip to the outside when the heat mode is being used. A RAD4 drain kit is available.
<b>WHIR!</b> 	The fan may run even when the compressor is not.



## If Something Goes Wrong

### Before You Call for Service

<b>Problem</b>	<b>Possible Causes</b>	<b>What to Do</b>
<b>Air Conditioner Doesn't Start</b>	The air conditioner is unplugged	<ul style="list-style-type: none"><li>• Make sure the air conditioner plug is pushed completely into the outlet.</li></ul>
	The fuse is blown/circuit breaker is tripped	<ul style="list-style-type: none"><li>• Check the house fuse/circuit breaker box and replace fuse or reset the breaker.</li></ul>
	Power failure	<ul style="list-style-type: none"><li>• If power failure occurs, turn the mode control to <b>OFF</b>. When power is restored, wait 3 minutes to restart the air conditioner to prevent tripping of the compressor overload.</li><li>• There is a protective time delay (up to 3 minutes) in the heat/cool and heat pump models. Wait 3 minutes for the air conditioner to resume heating or cooling.</li></ul>
<b>Air Conditioner Does Not Cool or Heat as it Should</b>	Airflow is restricted	<ul style="list-style-type: none"><li>• Make sure there are no curtains, blinds or furniture blocking the front of the air conditioner.</li></ul>
	The thermostat control may not be set high or low enough	<ul style="list-style-type: none"><li>• Turn the knob to a warmer or cooler setting. The coolest setting provides maximum cooling. The warmest setting provides maximum heating on models with heat.</li></ul>
	The air filter is dirty	<ul style="list-style-type: none"><li>• Clean the filter at least every 30 days. See the Care and Cleaning section.</li></ul>
	The room may have been hot or cold	<ul style="list-style-type: none"><li>• When the air conditioner is first turned on you need to allow time for the room to cool down or warm up.</li></ul>
	Cold air is escaping	<ul style="list-style-type: none"><li>• Check for open furnace floor registers and cold air returns.</li><li>• Set the exhaust vent in the closed position.</li></ul>
	Cooling coils have iced up	<ul style="list-style-type: none"><li>• See freezing up below.</li></ul>
<b>Air Conditioner Freezing Up</b>	Ice blocks the airflow and stops the air conditioner from cooling the room	<ul style="list-style-type: none"><li>• Set the mode control at <b>HIGH FAN</b> or <b>HIGH COOL</b> with the thermostat at a warmer setting.</li></ul>

---

## *Notes*

---

---

---

---

---

---

---

---

---

---

---

---

---

---

---

---

---

---

---

---

---

---

---

---

---

---

---

---



# GE Service Numbers

*We'll be there!*



## GE Answer Center®

**800.626.2000**

**TDD  
800-833-4322**

Open 24 hours a day,  
7 days a week.

## In-Home Repair Service

**800-GE-CARES  
(800-432-2737)**

We provide expert repair service,  
scheduled at a time that's  
convenient for you.

Our factory-trained technicians  
know your appliance inside and out—  
so most repairs can be handled in  
just one visit.

## Service Contracts

**800-626-2224**

With a service contract GE  
Consumer Service will still be there  
after your warranty expires.

With a multiple-year contract,  
you're assured of future service at  
today's prices.

## Parts and Accessories

**800-626-2002**

Individuals qualified to service  
their own appliances can have  
parts or accessories sent directly  
to their home.

VISA, MasterCard and Discover  
cards are accepted.

**Care and cleaning instructions con-  
tained in this manual cover proce-  
dures to be performed by any user.  
Other servicing generally should be  
referred to qualified service per-  
sonnel. Caution must be exercised,  
since improper servicing may cause  
unsafe operation.**

## Further Service

If for some reason you  
are not happy with the  
service you receive, here  
are three steps to follow  
for further help.

**First**, contact the people who ser-  
viced your appliance. Explain why  
you are not pleased.

**Next**, if you are still not pleased,  
write all the details—including  
your phone number—to:

Consumer Relations  
GE Appliances  
Louisville, KY 40225

**Finally**, if your problem is still  
not resolved, write:

Major Appliance  
Consumer Action Program  
20 North Wacker Drive  
Chicago, IL 60606



# AIR CONDITIONER WARRANTY

*Staple sales slip or cancelled check here. Proof of original purchase date is needed to obtain service under warranty.  
For service, call 800-GE-CARES.*

## What Is Covered

### FULL ONE-YEAR WARRANTY

For one year from date of original purchase, we will provide, free of charge, parts and service labor in your home to repair or replace *any part of the room air conditioner* that fails because of a manufacturing defect.

### FULL FIVE-YEAR WARRANTY

For five years from the date of original purchase, we will provide, free of charge, parts and service labor in your home to repair or replace *any part of the sealed refrigerating system* (the compressor, condenser, evaporator and all connecting tubing) that fails because of a manufacturing defect.

## What Is Not Covered

- Service trips to your home to teach you how to use the product.
- Improper installation.  
If you have an installation problem, or if the air conditioner is of improper cooling capacity for the intended use, contact your dealer or installer. You are responsible for providing adequate electrical connecting facilities.
- Replacement of house fuses or resetting of circuit breakers.
- In commercial locations labor necessary to move the unit to a location where it is accessible for service by an individual technician.
- Failure of the product resulting from modifications to the product or due to unreasonable use including failure to provide reasonable and necessary maintenance.
- Failure due to corrosion on models not corrosion-protected.
- Damage to product caused by improper power supply voltage, accident, fire, floods or acts of God.
- Incidental or consequential damage to personal property caused by possible defects with this air conditioner.

**Warrantor: General Electric Company. Louisville, KY 40225**

This warranty is extended to the original purchaser and any succeeding owner for products purchased for home use within the USA. In Alaska, the warranty excludes the cost of shipping or service calls to your home.

Some states do not allow the exclusion or limitation of incidental or consequential damages. This warranty gives you specific legal rights, and you may also have other rights which vary from state to state. To know what your legal rights are in your state, consult your local or state consumer affairs office or your state's Attorney General.