

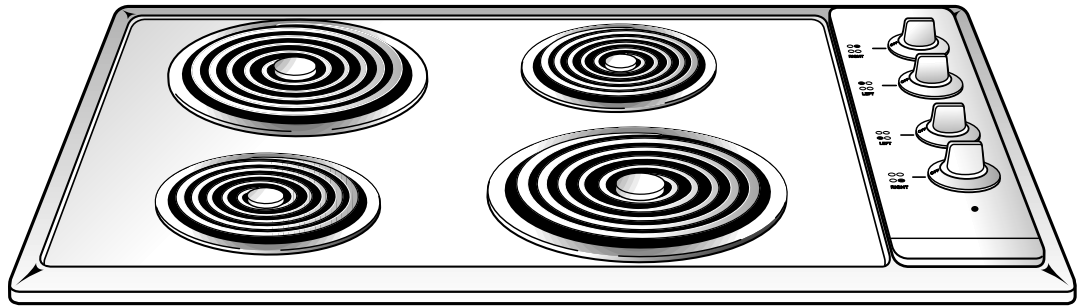

*GE Appliances*

Built-In Electric  
**COOKTOP**



**Owner's Manual**

*JP326*

*JP626*



<b>Safety Instructions</b>	<p><b>Safety Information</b>  <i>Safety Precautions</i> . . . . . 3–5</p>
<b>Operating Instructions</b>	<p><b>Operating Instructions</b>  <i>Using the Surface Units</i> . . . . . 6</p>
<b>Care and Cleaning</b>	<p><b>Care and Cleaning</b>  <i>Control Knobs</i> . . . . . 7  <i>Surface Units</i> . . . . . 8  <i>Lift-Up Cooktop</i> . . . . . 9</p>
<b>Troubleshooting Tips</b>	<p><b>Troubleshooting Tips</b>  <i>Before You Call For Service</i> . . . . . 10</p>
<b>Customer Service</b>	<p><b>Customer Service</b>  <i>Warranty</i> . . . . . 11  <i>Service Telephone Numbers</i> . . . . . Back Cover</p>

# Congratulations! You Are Now Part of the GE Family.

Welcome to the GE family. We're proud of our quality products and we are committed to providing dependable service. You'll see it in this easy-to-use Owner's Manual and you'll hear it in the friendly voices of our customer service department.

Best of all, you'll experience these values each time you use your cooktop. That's important, because your new cooktop will be part of your family for many years. And we hope you will be part of ours for a long time to come.

We thank you for buying GE. We appreciate your purchase, and hope you will continue to rely on us whenever you need quality appliances for your home.

## GE & You, A Service Partnership.



### IMPORTANT!

Fill out and return the Consumer Product Registration Card that is packed with this product.



### FOR YOUR RECORDS

**Write the model and serial numbers here:**

# \_\_\_\_\_  
 # \_\_\_\_\_

You can find them on a label on the wire cover under the cooktop.

**Staple sales slip or cancelled check here.**

Proof of the original purchase date is needed to obtain service under the warranty.



### READ THIS MANUAL

Inside you will find many helpful hints on how to use and maintain your cooktop properly. Just a little preventive care on your part can save you a great deal of time and money over the life of your cooktop.

You'll find many answers to common problems in the *Before You Call For Service* section. If you review our chart of *Troubleshooting Tips* first, you may not need to call for service at all.



### IF YOU NEED SERVICE

If you do need service, you can relax knowing help is only a phone call away. A list of toll-free customer service numbers is included in the back section of this manual. Or you can always call the GE Answer Center® at 800.626.2000, 24 hours a day, 7 days a week.

# IMPORTANT SAFETY INFORMATION. READ ALL INSTRUCTIONS BEFORE USING.

## **WARNING!**

For your safety, the information in this manual must be followed to minimize the risk of fire or explosion, electric shock, or to prevent property damage, personal injury, or loss of life.



## SAFETY PRECAUTIONS

When using electrical appliances, basic safety precautions should be followed, including the following:

- Use this appliance only for its intended use as described in this manual.
- Do not attempt to repair or replace any part of your cooktop unless it is specifically recommended in this manual. All other servicing should be referred to a qualified technician.
- Before performing any service, disconnect the cooktop power supply at the household distribution panel by removing the fuse or switching off the circuit breaker.
- Be sure your appliance is properly installed and grounded by a qualified technician in accordance with the provided installation instructions.
- Have the installer show you the location of the circuit breaker or fuse. Mark it for easy reference.
- Do not leave children alone—children should not be left alone or unattended in an area where an appliance is in use. They should never be allowed to sit or stand on any part of the appliance.
- Teach children not to play with the controls or any other part of the cooktop.
- Do not allow anyone to climb, stand or hang on the cooktop.
- **CAUTION:** Items of interest to children should not be stored in cabinets above a cooktop—children climbing on the cooktop to reach items could be seriously injured.
- Always keep combustible wall covering, curtains or drapes a safe distance from your cooktop.
- Always keep dish towels, dish cloths, pot holders and other linens a safe distance away from your cooktop.
- Always keep wooden and plastic utensils and canned food a safe distance away from your cooktop.
- Never wear loose-fitting or hanging garments while using the appliance. Flammable material could be ignited if brought in contact with hot surface units and may cause severe burns.
- Use only dry pot holders—moist or damp pot holders on hot surfaces may result in burns from steam. Do not let pot holders touch hot surface units. Do not use a towel or other bulky cloth. Such cloths can catch fire on a hot surface unit.



## WHEN COOKING PORK . . .

When cooking pork, follow the directions exactly and always cook the meat to an internal temperature of at least 170°F. This assures that, in the remote possibility that trichina may be present in the meat, it will be killed and the meat will be safe to eat.

## IMPORTANT SAFETY INFORMATION. READ ALL INSTRUCTIONS BEFORE USING.



### **⚠ WARNING!** SAFETY PRECAUTIONS

- For your safety, never use your appliance for warming or heating the room.
- Do not use water on grease fires. Never pick up a flaming pan. Turn the controls off. Smother a flaming pan on a surface unit by covering the pan completely with well fitting lid, cookie sheet or flat tray. Use a multi-purpose dry chemical or foam-type extinguisher.
- Flaming grease outside a pan can be put out by covering with baking soda or, if available, by using a multi-purpose dry chemical or foam-type fire extinguisher.
- When flaming foods are under the hood, turn the fan off. The fan, if operating, may spread the flames.
- Do not let cooking grease or other flammable materials accumulate on the cooktop.
- Do not touch surface units. These surfaces may be hot enough to burn even though they are dark in color. During and after use, do not touch, or let clothing or other flammable materials contact the surface units or areas nearby the surface units; allow sufficient time for cooling first.  
  
Potentially hot surfaces include the cooktop and areas facing the cooktop.
- To minimize the possibility of burns, ignition of flammable materials and spillage, the handle of a container should be turned toward the center of the cooktop without extending over any nearby surface units.
- Always turn the surface unit control to off before removing the cookware.
- To avoid the possibility of a burn or electric shock, always be certain that the controls for all surface units are at off position and all coils are cool before attempting to lift or remove the unit.
- Do not immerse or soak removable surface units. Do not put them in a dishwasher.
- Use proper pan size—Select cookware having flat bottoms large enough to cover the surface unit heating element. The use of undersized cookware will expose a portion of the surface unit to direct contact and may result in ignition of clothing. Proper relationship of cookware to burner will also improve efficiency.
- Never leave surface units unattended at high heat settings. Boilovers cause smoking and greasy spillovers that may catch on fire.
- Be sure the drip pans are not covered and are in place. Their absence during cooking could damage cooktop parts and wiring.
- Do not use aluminum foil to line the drip pans. Misuse could result in a shock, fire hazard or damage to the cooktop.

- Only certain types of glass, glass/ceramic, earthenware or other glazed containers are suitable for cooktop cooking; others may break because of the sudden change in temperature.
- Never clean the cooktop surface when it is hot. Some cleaners produce noxious fumes and wet cloths could cause steam burns if used on a hot surface.
- Keep an eye on foods being fried at high or medium high heat settings.
- Foods for frying should be as dry as possible. Frost on frozen foods or moisture on fresh foods can cause hot fat to bubble up and over the sides of the pan.
- Use little fat for effective shallow or deep-fat frying. Filling the pan too full of fat can cause spillovers when food is added.
- If a combination of oils or fats will be used in frying, stir together before heating, or as fats melt slowly.
- Always heat fat slowly, and watch as it heats.
- Use a deep fat thermometer whenever possible to prevent overheating fat beyond the smoking point.
- Never try to move a pan of hot fat, especially a deep fat fryer. Wait until the fat is cool.
- Do not store flammable materials near the cooktop.
- Keep the hood and grease filters clean to maintain good venting and to avoid grease fires.
- Do not store or use combustible materials, gasoline or other flammable vapors and liquids in the vicinity of this or any appliance.
- Clean only parts listed in this Owner's Manual.
- Do not leave paper products, cooking utensils or food on the cooktop when not in use.
- Keep cooktop clean and free of accumulation of grease or spillovers which may ignite.
- Never heat unopened food containers. Pressure buildup may make container burst and cause injury.
- Never leave jars or cans of fat drippings on or near your cooktop.



*Read and follow this Safety Information carefully.*

**SAVE THESE INSTRUCTIONS**

## Using the surface units.

Throughout this manual, features and appearance may vary from your model.

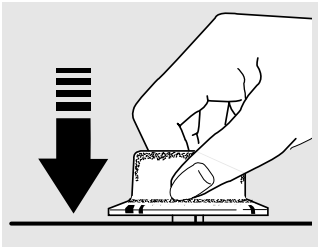

### How to Set

Push the knob in and turn in either direction to the setting you want.

At both **OFF** and **HI** the control **clicks** into position. You may hear slight **clicking** sounds during cooking, indicating the control is keeping the power level you set.

The control must be pushed in to set only from the **OFF** position. When the control is in any position other than **OFF**, it may be rotated without pushing it in.

An indicator light will glow when **any** surface unit is on.

Be sure you turn the control knob to **OFF** when you finish cooking.

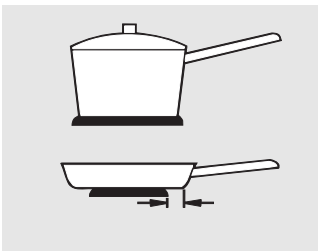

Not over 1 inch.

### Surface Cookware Tips

Use medium- or heavy-weight cookware. Aluminum cookware conducts heat faster than other metals. Cast-iron and coated cast-iron cookware are slow to absorb heat, but generally cook evenly at low to medium heat settings. Steel pans may cook unevenly if not combined with other metals.

For best cooking results, pans should be flat on the bottom. Match the size of the saucepan to the size of the surface unit. The pan should not extend over the edge of the surface unit more than 1 inch.

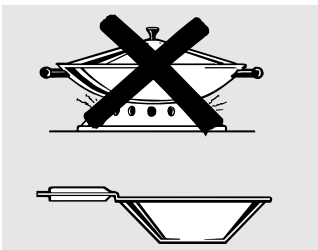

Use only flat-bottomed woks.

### Wok Cooking

We recommend that you use only a flat-bottomed wok. They are available at your local retail store.

Do not use woks that have support rings. Use of these types of woks, with or without the ring in place, can be dangerous.

Placing the ring over the surface unit will cause a build-up of heat that will damage the porcelain cooktop. Do not try to use such woks without the ring. You could be seriously burned if the wok tipped over.

### Deep Fat Frying

Do not overfill cookware with fat that may spill over when adding food. Frosty foods bubble vigorously.

Watch food frying at high temperatures. Keep cooktop and hood clean from grease.

## Care and cleaning of the cooktop.

Be sure electrical power is off and all surfaces are cool before cleaning any part of the cooktop.

### How to Remove Packaging Tape

To assure no damage is done to the finish of the product, the safest way to remove the adhesive left from packaging tape on new appliances is an application of a household liquid dishwashing detergent, mineral oil or cooking oil.

Apply with a soft cloth and allow to soak. Wipe dry and then apply an appliance polish to thoroughly clean and protect the surface.

**NOTE:** The plastic tape must be removed from all chrome trim. It cannot be removed if it is baked on.

### Glass Control Panel

The glass control panel on your cooktop has been tempered to withstand sudden temperature changes during cooking. Give it the normal care you would give any glass material.

While it is impact-resistant, avoid scratching it to prevent it from shattering.

If the glass is hot, wipe up spills with a dry cloth or paper towel. When the surface has cooled, wash, rinse and dry it. Alternately, when the glass is cool, spray it with glass or window cleaner. Avoid the use of cleaning powders or harsh abrasives that may scratch the surface.

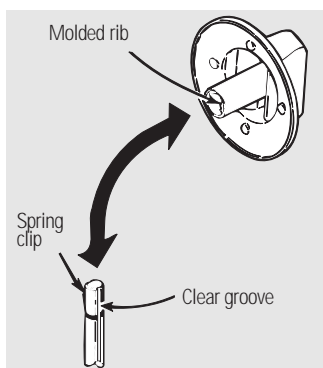

### Control Knobs

The control knobs may be removed for easier cleaning.

Before removing the knobs for cleaning, please note that the knobs are in the **OFF** position. When replacing the knobs, check the **OFF** position to insure proper placement.

The knob has a groove in each side. The groove on one side has a spring clip. The other groove is clear. Check the inside of the knob and find the molded rib.

Wash knobs in soap and water but do not soak. Avoid getting water down into the knob stem holes.

Replace the knob by fitting the molded rib inside the knob into the clear groove on the stem.

### Brushed Chrome Cooktop (on some models)

Clean the brushed chrome top with warm, soapy water or Bon Ami® brand cleanser. Rinse and immediately dry it with a clean, soft cloth. Take care to dry the surface following the “grain.”

To help prevent finger marks after cleaning, spread a thin film of baby oil on the surface or a chrome protectant may be used to help reduce spotting or fingerprinting. Wipe away excess oil with a clean, soft cloth.

## Care and cleaning of the cooktop.

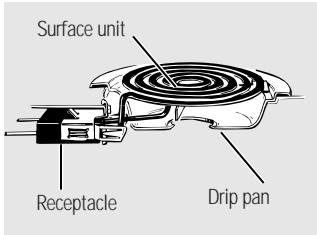

### Surface Units

To clean the surface units, turn the control to the highest setting for a minute. The coils will burn off any soil.

#### To remove a surface unit:

To remove the drip pans for cleaning, the surface units must be removed first.

Lift the surface unit about 1 inch above the drip pan and pull it out.

Do not lift the surface unit more than 1 inch. If you do, it may not lie flat on the drip pan when you plug it back in.

Repeated lifting of the surface unit more than 1 inch above the drip pan can permanently damage the receptacle.

#### To replace a surface unit:

Replace the drip pan into the recess in the cooktop. Make sure the opening in the pan lines up with the receptacle.

Insert the terminals of the surface unit through the opening in the drip pan and into the receptacle.

Guide the surface unit into place so it rests evenly.

*Do not immerse the surface units in liquids of any kind.*

*Do not clean the surface units in a dishwasher.*

*Do not bend the surface unit plug terminals.*

*Do not attempt to clean, adjust or in any way repair the plug-in receptacle.*

### Drip Pans

Remove the surface units. Then lift out the drip pans.

For best results, clean the drip pans by hand. Place them in a covered container (or a plastic bag) with 1/4 cup ammonia to loosen the soil. Then scrub with a soap-filled scouring pad if necessary. Rinse with clean water and polish with a clean soft cloth.

The drip pans may also be cleaned in a dishwasher.

Clean the area under the drip pans often. Built-up soil, especially grease, may catch fire.

*Do not cover the drip pans with foil. Using foil so close to the receptacle could cause shock, fire or damage to the cooktop.*

### Porcelain Enamel Cooktop (on some models)

The porcelain enamel finish is sturdy but breakable if misused. This finish is acid-resistant. However, any acidic foods spilled (such as fruit juices, tomato or vinegar) should not be permitted to remain on the finish.

*If acids spill on the cooktop while it is hot, use a dry paper towel or cloth to wipe it up right away. When the surface has cooled, wash with soap and water. Rinse well.*

For other spills such as fat splatterings, wash with soap and water or cleansing powders after the surface has cooled. Rinse well. Polish with a dry cloth.



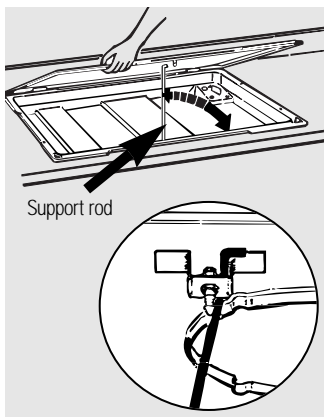

Be sure to secure the cooktop support rod in the cooktop strike catch.

### Lift-Up Cooktop

Clean the area under the cooktop often. Built-up soil, especially grease, may catch on fire.

#### To raise the cooktop:

Be sure all surface units are turned off before raising the cooktop. To make cleaning easier, the entire cooktop may be lifted. It can be easily lifted by removing one of the surface units and grasping the opening of the cooktop. Raise the support rod into place and hook it into the bracket on the underside of the cooktop to hold the cooktop while cleaning. Be sure to secure the cooktop support rod in the cooktop strike catch.

#### To lower the cooktop:

After cleaning under the cooktop with hot, mild soapy water and a clean cloth, lower the cooktop. Be careful not to pinch your fingers. Carefully replace the support rod and lower the cooktop. Press into place. Make sure the strikes fit in the catches to fasten the cooktop. Replace the four drip pans, surface units and control knobs.

### Metal Parts

Do not use steel wool, abrasives, ammonia or commercial oven cleaners. To safely clean surfaces; wash, rinse and then dry with a soft cloth.

## Before You Call For Service...



### Troubleshooting Tips

Save time and money! Review the chart on this page first and you may not need to call for service.

<b>Problem</b>	<b>Possible Causes</b>	<b>What To Do</b>
<b>Surface units not functioning properly</b>	<b>The surface units are not plugged in solidly.</b>	<ul style="list-style-type: none"> <li>• With the controls off, check to make sure the surface unit is plugged completely into the receptacle.</li> </ul>
	<b>The surface unit controls improperly set.</b>	<ul style="list-style-type: none"> <li>• Check to see the correct control is set for the surface unit you are using.</li> </ul>
	<b>The drip pans are not set securely in the cooktop.</b>	<ul style="list-style-type: none"> <li>• With the controls off, check to make sure the drip pan is in the recess in the cooktop and that the opening in the pan lines up with the receptacle.</li> </ul>
	<b>A fuse in your home may be blown or the circuit breaker tripped.</b>	<ul style="list-style-type: none"> <li>• Replace the fuse or reset the circuit breaker.</li> </ul>

# GE Built-In Cooktop Warranty



All warranty service provided by our Factory Service Centers or an authorized Customer Care® technician. For service, call 800-GE-CARES.

## For The Period Of: **GE Will Replace, At No Charge To You:**

**One Year**  
From the date of the original purchase

**Any part** of the cooktop which fails due to a defect in materials or workmanship. During this **full one-year warranty**, GE will also provide, **free of charge**, all labor and in-home service to replace the defective part.

## What GE Will Not Cover:

- Service trips to your home to teach you how to use the product.
- Replacement of house fuses or resetting of circuit breakers.
- Improper installation.
- Damage to the product caused by accident, fire, floods or acts of God.
- Failure of the product if it is abused, misused, or used for other than the intended purpose or used commercially.
- Incidental or consequential damage to personal property caused by possible defects with this appliance.

*This warranty is extended to the original purchaser and any succeeding owner for products purchased for home use within the USA. In Alaska, the warranty excludes the cost of shipping or service calls to your home.*

*Some states do not allow the exclusion or limitation of incidental or consequential damages. This warranty gives you specific legal rights, and you may also have other rights which vary from state to state. To know what your legal rights are, consult your local or state consumer affairs office or your state's Attorney General.*

Warrantor: General Electric Company, Louisville, KY 40225

Safety Instructions

Operating Instructions

Care and Cleaning

Troubleshooting Tips

Customer Service

## Service Telephone Numbers.



### GE Answer Center® 800.626.2000

The GE Answer Center® is open 24 hours a day, 7 days a week.



### In-Home Repair Service 800-GE-CARES (800-432-2737)

Expert GE repair service is only a phone call away.

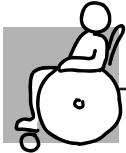

### Special Needs Service 800.626.2000

#### 800-TDD-GEAC (800-833-4322)

GE offers, free of charge, a brochure to assist in planning a barrier-free kitchen for persons with limited mobility.



### Service Contracts 800-626-2224

Purchase a GE service contract while your warranty is still in effect and you'll receive a substantial discount. GE Consumer Service will still be there after your warranty expires.

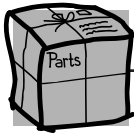

### Parts and Accessories 800-626-2002

Individuals qualified to service their own appliances can have parts or accessories sent directly to their homes (VISA, MasterCard and Discover cards are accepted).

*Instructions contained in this manual cover procedures to be performed by any user. Other servicing generally should be referred to qualified service personnel. Caution must be exercised, since improper servicing may cause unsafe operation.*



### Service Satisfaction

If you are not satisfied with the service you receive from GE:

**First**, contact the people who serviced your appliance.

**Next**, if you are still not pleased, write all the details—including your phone number—to:

Manager, Consumer Relations  
GE Appliances  
Appliance Park  
Louisville, KY 40225

**Finally**, if your problem is still not resolved, write:

Major Appliance Consumer Action Program  
20 North Wacker Drive  
Chicago, IL 60606