

5.58 Cubic Foot 48-Bottle Capacity Built-In Wine Cellar

WC200GS



Available

Unit Specifications

Width	23 7/8"
Depth	25 1/2" (including handle)
Height	34 9/16" (including hinge)
Weight	130.1 lbs.
UPC	688057381961

More Easy-To-Use Features

- Stainless steel door with 3/4" pro style handle
- Soft lighting (auto/manual)
- Four glide-out shelves with wood trim
- Glide-out storage basket
- Reversible door (for right or left swing)
- Leveling legs

Available Finishes



Stainless Steel

Signature Features

Electronic Controls

Features Celsius and Fahrenheit options

Sabbath Mode

Disables functions in accordance with Shabbat-observing practices

Dual Zone Temperature Management

Includes a moveable divider so that zones can be individually sized and controlled

Optimized Temperature Range

Offers an upper zone (50°F–65°F) and lower zone (43°F–65°F)

ADA

Cutout Dimensions		in.
Height		35"
Depth (including handle)		24"
Width		24"
Depth (door open 90°)		46.37"
Overall Packaging Details		
Packaging		lb./in.
Gross Weight		145.3 lbs.
Dimensions	W	26 1/4"
	D	28 1/4"
	H	37 1/4"
Power Requirements		
Electrical Rating		115V, 60Hz

Product Technical Illustration

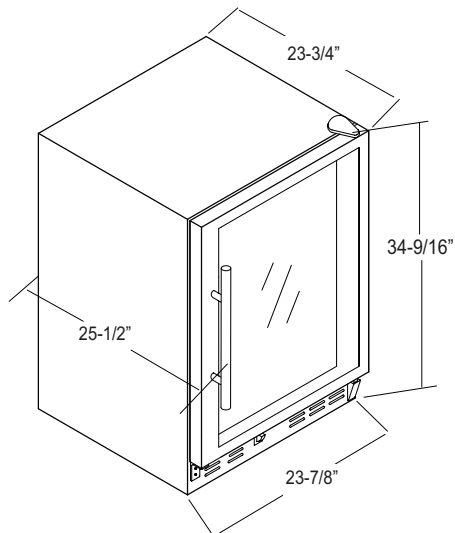

General Appliance Information

Please read all installation details and instructions before use.

Contact Us

For questions regarding this product please refer to our website at haieramerica.com or call our customer service center at 877-337-3639.

